



Purity beyond expectations

Water supply for the Sugözü Power Plant

Case Story



The Sugözü Power Plant in Turkey began commercial operation in November 2003. It is a 1210 MW IPP (independent power producer) coal-fired power plant, owned and operated by ISKEN (İskenderun Enerji Üretim Ve Ticaret A.S.), a special-purpose joint stock company. The major shareholder is STEAG, Germany's leading producer of coal-based electricity.

STEAG contracted German-based Siemens AG to build the plant, based on this company's previous experience in building large power plants, as well as its advanced technology.

The power plant is located at Iskenderun Bay, close to the city of Adana, on the eastern Mediterranean coast of Turkey. Fresh water is scarce in this region and natural water is reserved for human and agricultural use. A desalination plant was therefore included as an integral part of the project.

Water supply

A sustainable, reliable supply of water was needed for boiler make-up, flue gas cleaning and other process requirements. After careful analysis, a steam-driven multiple effect desalination plant was considered the best option. The evaporative desalination process used in this type of plant produces high-quality water with a low dissolved solids content.

Water demineralization is then achieved by a simple mixed-bed ion exchange method with significantly reduced chemical consumption for regeneration compared with traditional ion-exchange columns.

Siemens, STEAG and their specialist consultants thoroughly evaluated and compared available technologies and brands for multiple effect desalination, and chose Alfa Laval to supply the desalination plant. Alfa Laval designed and supplied the complete plant, which was installed by Siemens using Alfa Laval supervisors. After installation, Alfa Laval commissioned the plant and carried out an extensive performance test on each unit. Alfa Laval guaranteed that the water produced would have a maximum TDS (total dissolved solids) of ten ppm (parts per million). In fact, the actual water produced only contains three to five ppm.

According to ISKEN's chemical department manager, Mr Mehmet Topeli, who is responsible for the plant and its operation, "The generated water is much purer than we expected, and this significantly reduces the cost of further treatment. Alfa Laval has shown great interest in this installation, and provided the necessary support. We have had several visits from Alfa Laval since we started the operation, which has prevented problems from arising."

Desalination installation

The desalination installation at the Sugözü Power Plant consists of three Alfa Laval TVC-4-1750 units, each of which has a capacity of 1750 m³ (460,000 gal) per day, corresponding to 50% of the anticipated water requirements.

The desalination units are powered by thermal energy, taken as bleed steam from the power plants' turbines, supplied at a pressure of 15 bar. Because the steam has already been used for generating power, its production cost is greatly reduced. The pressure energy of the steam is used in a thermal vapour compressor (TVC) to recycle and compress vapour in the system, which increases the heating energy available for the process.

Steam from the TVC is used as the heat source for the part evaporation of sea water. This is done by moving the steam over a heating surface – made of high-grade corrosion-resistant titanium plates – to the seawater feed on the opposite side of the plates. The heat partly evaporates some of the sea water as pure water vapour. The water vapour is then utilized as the evaporation energy for the subsequent effect, where the same process is repeated four times. The water vapour generated from the last effect is condensed in the main system condenser cooled by sea water.

A dedicated PLC (programmable logic control) system means the desalination units operate fully automatically with start-up and capacity control in accordance with the level in the distillate storage tanks.

Special features

One of the special features of the Alfa Laval thermal desalination concept is the configuration of the condensation/evaporation heat transfer surface, which is based on thin titanium plates with a falling film configuration. The plate yields a high thermal efficiency, which results in more compact units with low weight and footprint. The fully controlled falling film reduces the tendency for scaling. These units have particularly long service lives because they are made of high-grade corrosion-resistant materials, such as titanium.

The modular design is based on well proven and thoroughly tested units, and meets any specified operating requirements.

Alfa Laval desalination units enable traditional cleaning-in-place (CIP). In addition, they are the only such units on the market that enable the plate heat exchangers to be disassembled for full physical cleaning, should that be required.

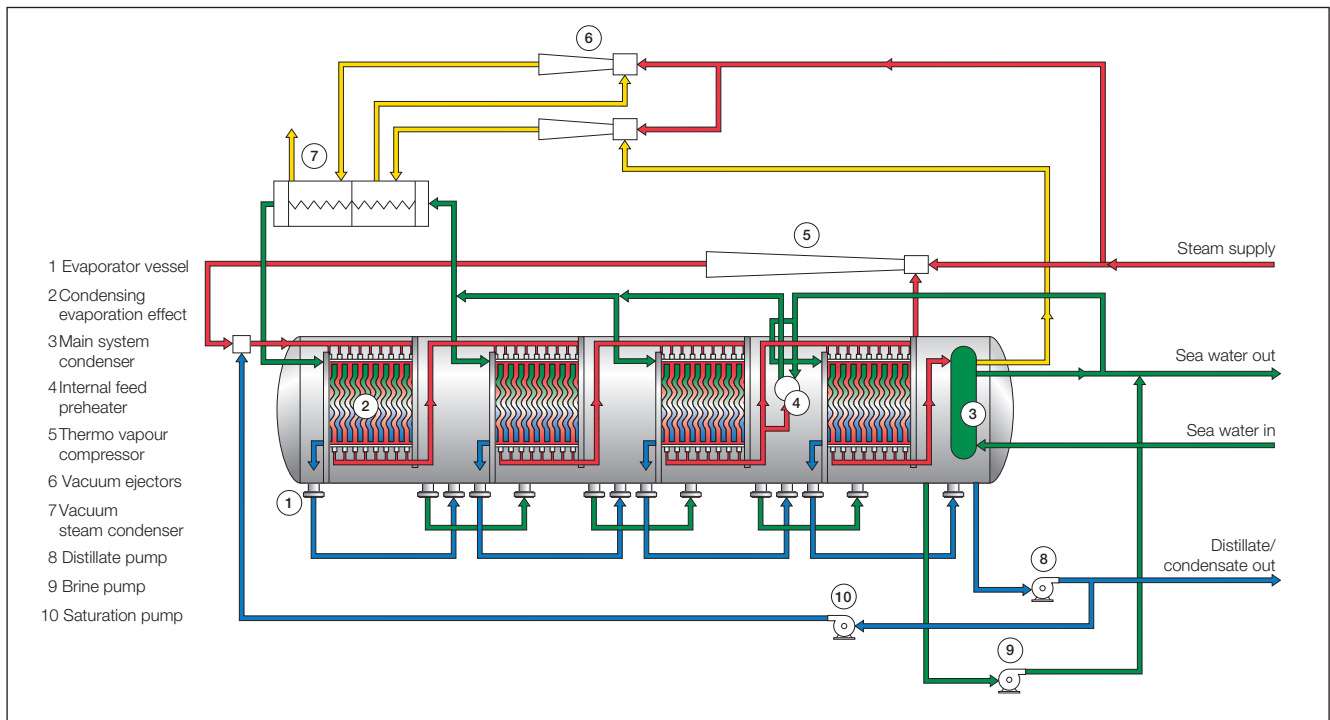

Fig. 1. The TVC process

How to contact Alfa Laval

Up-to-date Alfa Laval contact details for all countries are always available on our website at www.alfalaval.com